

Rectifier Diode

W1748LC080 to W1748LC220

The data sheet on the subsequent pages of this document is a scanned copy of existing data for this product.
(Rating Report 87NR9 Issue 1)

This data reflects the old part number for this product which is: **SW02-22CXC805**. This part number must **NOT** be used for ordering purposes – please use the ordering particulars detailed below.

The limitations of this data are as follows:
Device not available for grades 02 to 06 (200V to 600
No reverse recovery information available

Please use the following link to view an up to date outline drawing for this device
[Outline W4](#)

Where any information on the product matrix page differs from that in the following data, the product matrix must be considered correct

An electronic data sheet for this product is presently in preparation.

For further information on this product, please contact your local ASM or distributor.

Ordering Particulars			
W1748	LC	◆◆	0
Fixed Type Code	Fixed Outline Code	Voltage code $V_{DRM}/100$ 08-22	Fixed Code
Typical Order Code: W1748LC200, 27mm clamp height, 2000V V_{RRM}			

IXYS Semiconductor GmbH
Edisonstraße 15
D-68623 Lampertheim
Tel: +49 6206 503-0
Fax: +49 6206 503-627
E-mail: marcom@ixys.de

WESTCODE
An IXYS Company

Westcode Semiconductors Ltd
Langley Park Way, Langley Park,
Chippenham, Wiltshire, SN15 1GE.
Tel: +44 (0)1249 444524
Fax: +44 (0)1249 659448
E-mail: WSL.sales@westcode.com

IXYS Corporation
3540 Bassett Street
Santa Clara CA 95054 USA
Tel: +1 (408) 982 0700
Fax: +1 (408) 496 0670
E-mail: sales@ixys.net

www.westcode.com

www.ixys.com

Westcode Semiconductors Inc
3270 Cherry Avenue
Long Beach CA 90807 USA
Tel: +1 (562) 595 6971
Fax: +1 (562) 595 8182
E-mail: WSI.sales@westcode.com

The information contained herein is confidential and is protected by Copyright. The information may not be used or disclosed except with the written permission of and in the manner permitted by the proprietors Westcode Semiconductors Ltd.

© Westcode Semiconductors Ltd.

In the interest of product improvement, Westcode reserves the right to change specifications at any time without prior notice.

Devices with a suffix code (2-letter, 3-letter or letter/digit/letter combination) added to their generic code are not necessarily subject to the conditions and limits contained in this report.

QUALITY EVALUATION LABORATORY

Rating Report: 87NR9

Date: 11th June, 1987

Pages: 10

Diode Type SW02-22CX805

Written by: *mfw. Dunlop*

Checked: *mfw.*

Approved: *[Signature]*

This diode consists of an all-diffused 38 mm diameter silicon slice mounted in a cold weld capsule housing. This report supersedes Rating Report No. 78NR12.

Ratings

Voltage Grades	:	02-22
V_{RSM}	:	300-2300V
V_{RRM}	:	200-2200V
$I_{F(AV)}$: Single Phase; 50 Hz, 180° half sinewave;		
Double side cooled $T_{HS} = 55^{\circ}C, 100^{\circ}C$:	1750A; 1300A
Single side cooled $T_{HS} = 100^{\circ}C$:	808A
I_F (rms) max.)	:	3160A
) Double side cooled $T_{HS} = 25^{\circ}C$		
I_F max.)	:	2760A
I_{FSM} : t = 10ms half sinewave; T_J (initial) = 175°C;		
$V_{RM} = 0.6 V_{RRM}(\text{Max})$:	15,400A
I_{FSM} ; t = 10ms half sinewave; T_J (initial) = 175 °C; $V_{RM} \leq 10V$:	17,700A
I^2t : t = 10ms; T_J (initial) = 175 °C; $V_{RM} = 0.6 V_{RRM}(\text{Max})$:	$1.19 \times 10^6 A^2 SECS$
I^2t : t = 10ms; T_J (initial) = 175 °C; $V_{RM} \leq 10V$:	$1.57 \times 10^6 A^2 SECS$
I^2t : t = 3ms; T_J (initial) = 175 °C; $V_{RM} \leq 10V$:	$1.16 \times 10^6 A^2 SECS$
T_{HS} Operating range	:	-40 to 175°C
T_{stg} ; Non-operating	:	-40 to 200°C

Characteristics

(Maximum values unless stated otherwise)

$V_O : T_J = 175^\circ\text{C}$:	0.87V
$r_s : T_J = 175^\circ\text{C}$:	0.28mohms
$V_{FM} : I_{FM} = 3770A \quad T_{VJ} = 175^\circ\text{C}$:	1.93V
$R_{th} (J-HS)$ Double side cooled	:	0.033°C/W
Single side cooled	:	0.065°C/W
$I_{RRM} : T_J = 175^\circ\text{C} \quad V_{RM} = V_{RRM}(\text{Max})$:	30mA
$Q_{rr} : I_{TM} = \quad dI/dt =$:	
$V_{RM} = \quad T_{VJ} =$:	
Mounting Force	:	1000-2000Kg.f
Outline drawing	:	100A243
Jedec Outline No.	:	DO-200AB

CONTENTS

	<u>Page</u>
Ratings	1
Characteristics	2
Contents	3
Voltage Ratings	4
Dissipation and Heatsink Temperature vs Mean Current	5 & 6
Limit Forward Voltage Characteristic	7
Transient Thermal Impedance Characteristic.	8
Surge Current and I^2t vs Duration of Surge	9
Outline Drawing	10

Changes to Rating Report No. 78NR12

p1 : $I_{T(AV)}$ at $T_{HS} = 55^\circ\text{C}$ changed)
" " = 100°C added) D.S.C.
" " = 100°C changed - S.S.C.

I^2t_1)
") corrected
 I^2t_2)

$T_{HS} (\text{MIN})$ reduced to -40°C

p2 : JEDEC outline No. added

pp5-9 : Re-drawn with changes on p5 and p6.

Voltage Ratings

Voltage Class SW	V _{RRM}	V _{RSM} V
02	200	300
04	400	500
06	600	700
08	800	900
10	1000	1100
12	1200	1300
14	1400	1500
16	1600	1700
18	1800	1900
20	2000	2100
22	2200	2300

This report is applicable to higher or lower voltage grades when supply has been agreed by Sales/Production.

DOUBLE SIDE COOLED

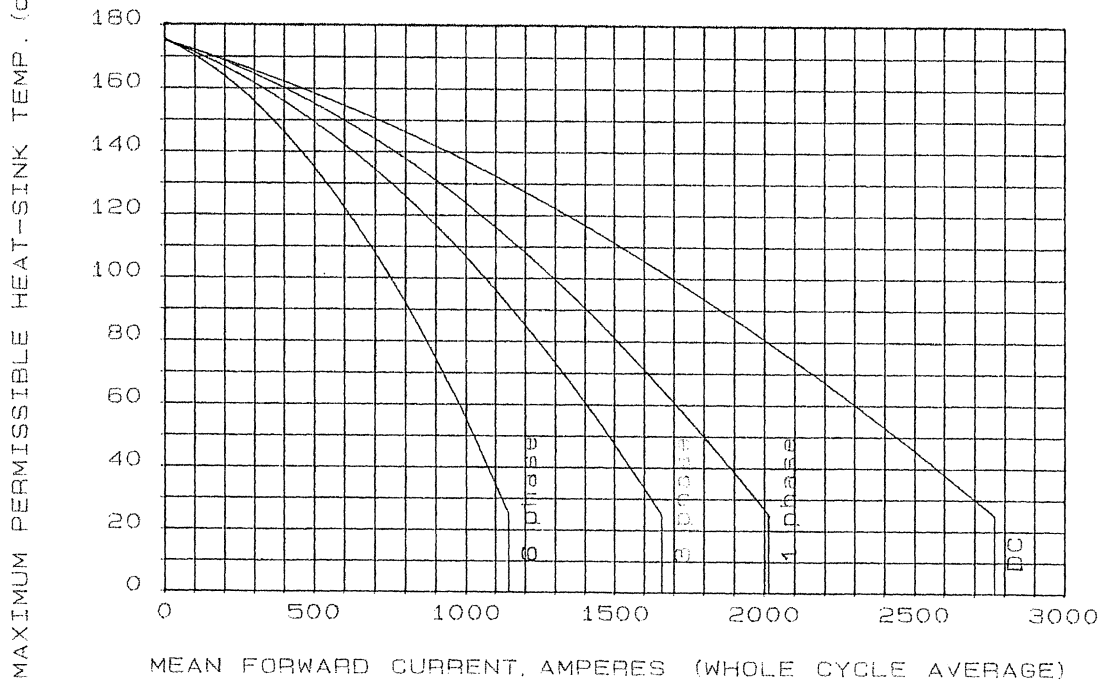
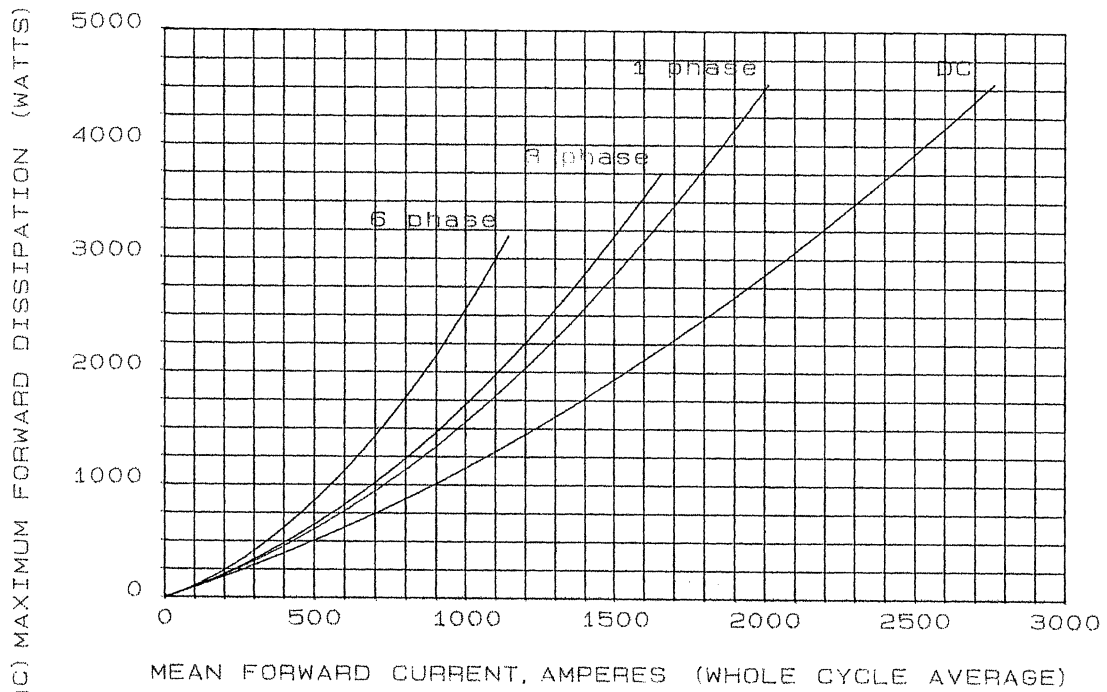

SINGLE SIDE COOLED

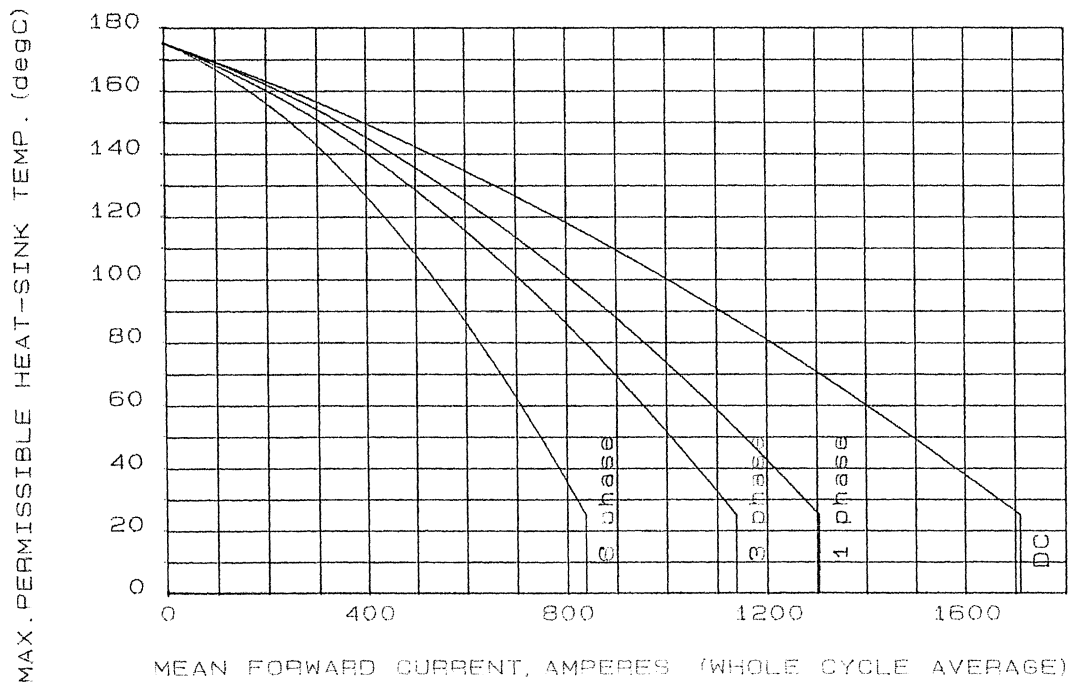
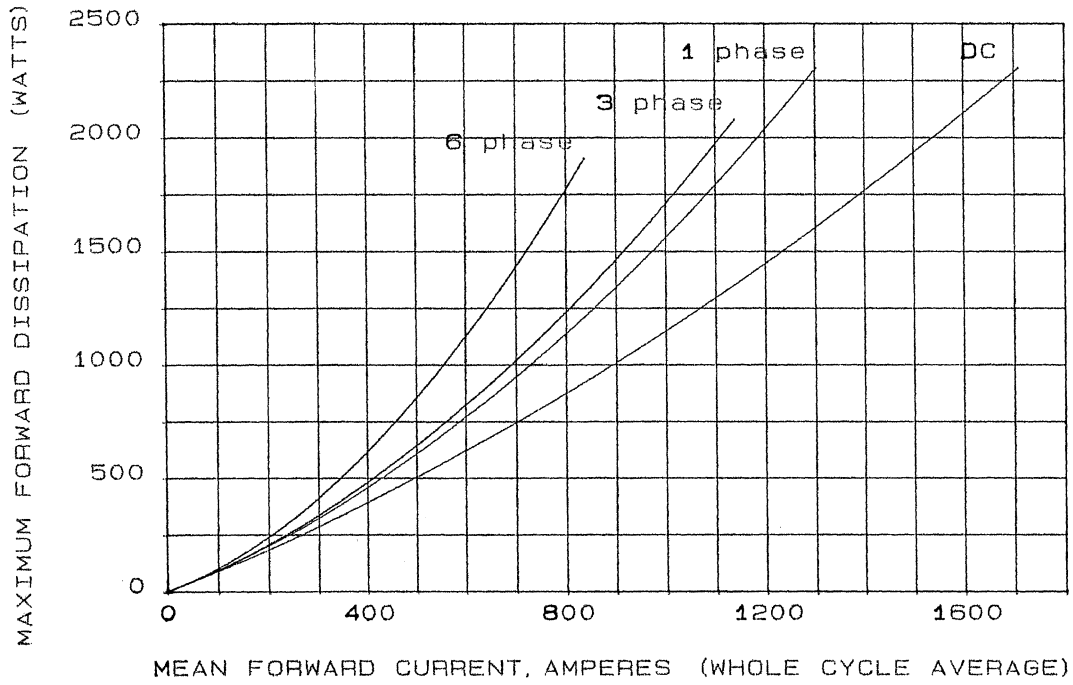

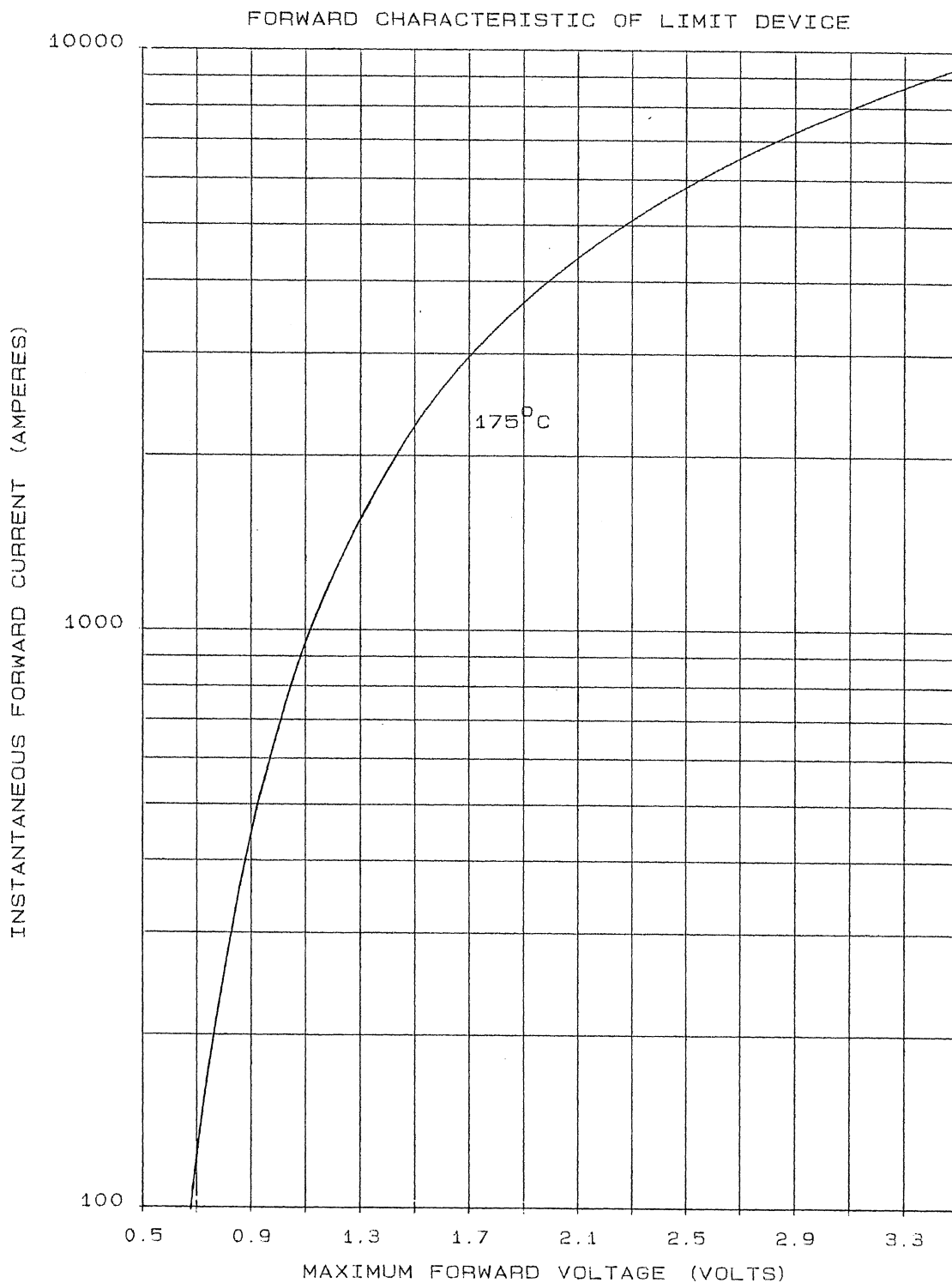

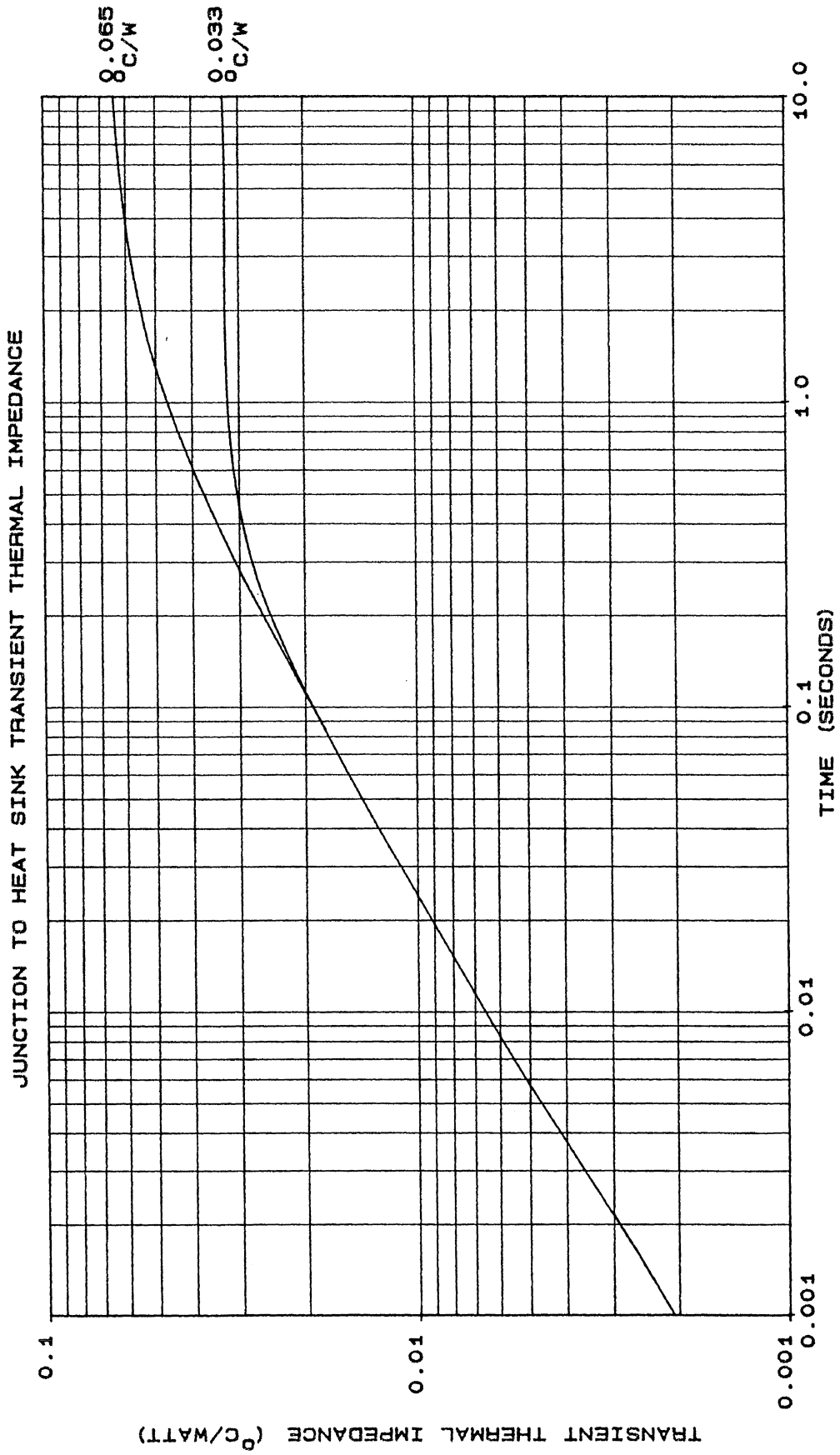

MAXIMUM NON REPETITIVE SURGE CURRENT AT INITIAL JUNCTION TEMPERATURE 175°C

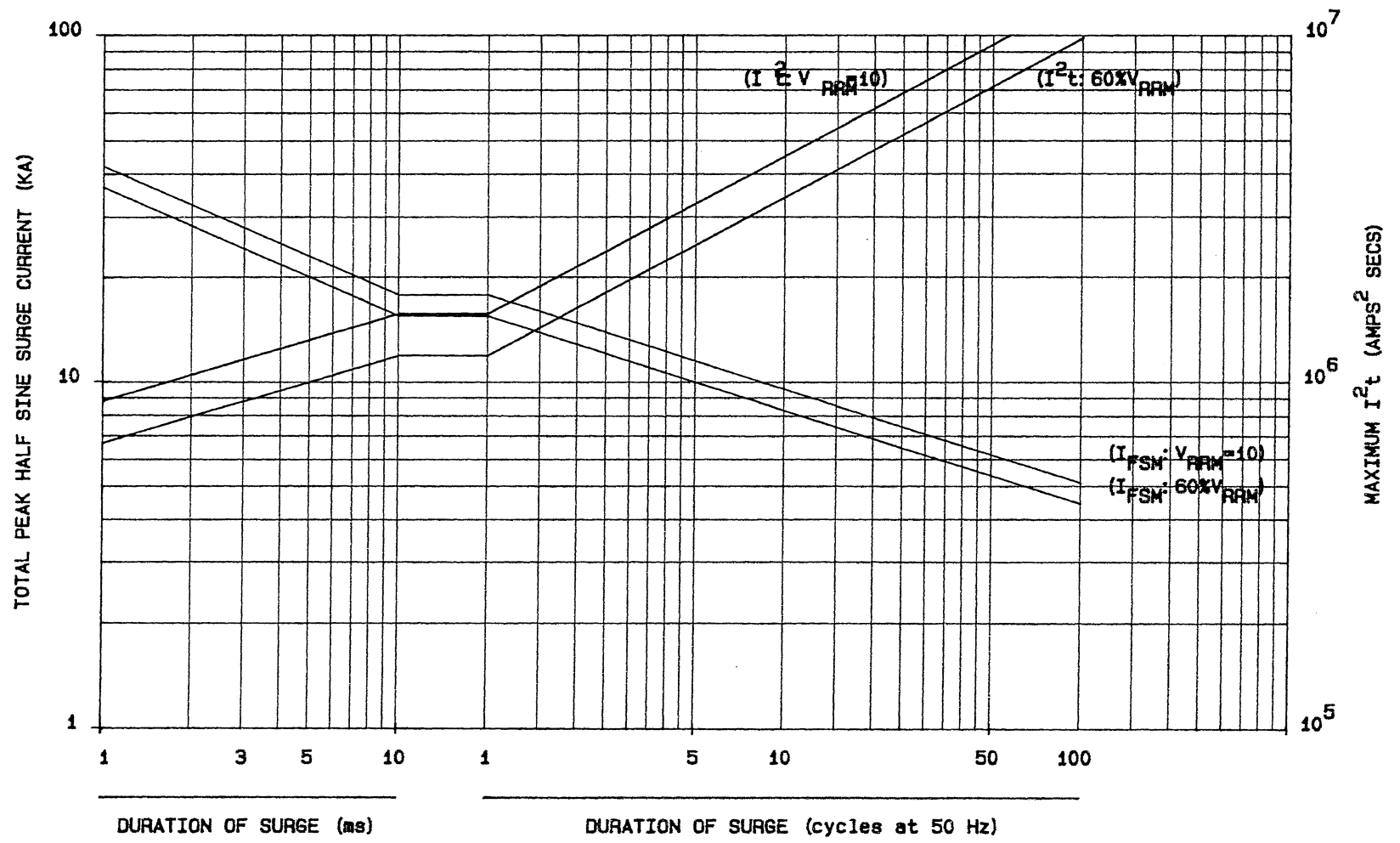

SCALE	1/1
DRN	<i>[Signature]</i>
CHKD	<i>[Signature]</i>
APPD	
	GEC-1
	CS 1
	QA 1
	LP 2
	HP 2
	A
S	NI

INTERNATIONAL OUTLINE No. **DO-200AB**
 WEIGHT. **340 GRAMS.** - 10 -
 FINISH. **ET TO BS 1872**
 DEVICE MARKING INCLUDES MONOGRAM, TYPE No., SPEC. No. AND POLARITY SYMBOL.
 DEVICE MOUNTING: CLAMPING FORCE: **1000 - 2000 kgf.**

CXC 935	CXC 220
CXC 805	CXC 224
CXC 525	CXC 474
CXC 505	CXC 524
CXC 515	CXC 724
CXC 374	

CLAMPING FORCE TO BE APPLIED ON ϕ OF LOCATION HOLES & BE EVENLY DISTRIBUTED OVER AREA OF CONTACT. FLATNESS TOL ON SURFACES TO WHICH DEVICE IS CLAMPED TO BE 0.04 WIDE.

G.A. DRG. No. **159B100H204**

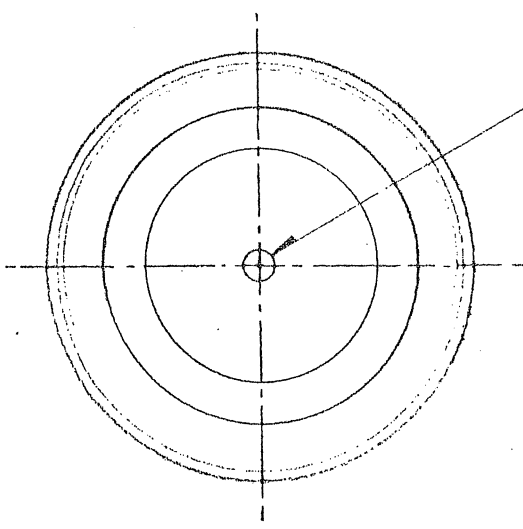

$\phi 3.6/3.5 \times 1.9$ MIN DEPTH 2-HOLES. ONE IN CATHODE AND ONE IN ANODE.

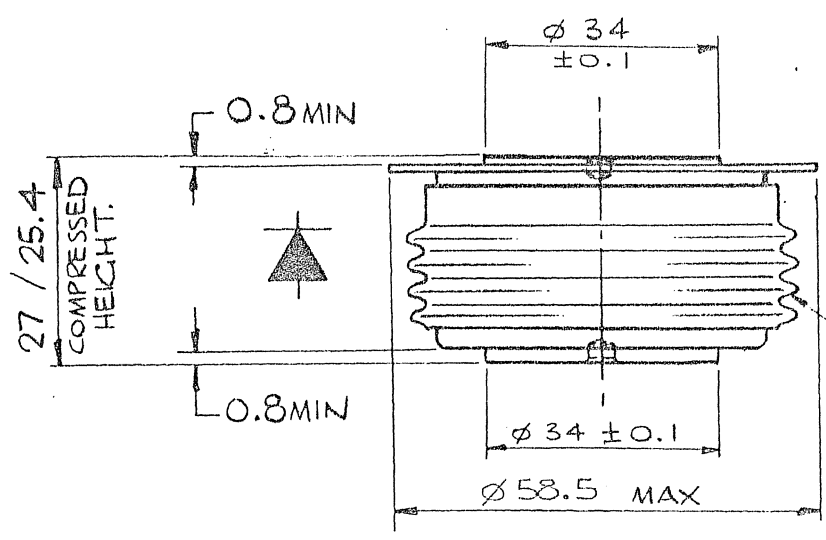

CREEP PATH 25 MIN.

THE INFORMATION CONTAINED IN THIS DRAWING IS SUPPLIED IN CONFIDENCE AND IS PROTECTED BY COPYRIGHT. THE INFORMATION MAY NOT BE DISCLOSED EXCEPT WITH THE WRITTEN PERMISSION OF AND IN MANNER PERMITTED BY THE PROPRIETORS, WESTINGHOUSE BRAKE AND SIGNAL CO. LTD.

WESTINGHOUSE BRAKE AND SIGNAL CO. LTD.
 CHIPPENHAM, WILTSHIRE, SN15 1JD, ENGLAND.

WESTCODE[®]
 SEMICONDUCTORS

THIRD ANGLE PROJECTION

DIMNS. IN MILLIMETRES

DRG. No. **100A243**

ISS	REVISIONS
1	7.9.77 P188
2	P30.4 15.5.78 $\phi 34$ WAS $\phi 38$, 1.9 MIN. WAS 3 MIN. 0.8 MIN WAS 0.5 & 1.5 MIN. <i>bs</i>
3	12.9.78 WAS $\phi 58.5$ WAS $\phi 60$. CLAMP FORCE WAS 200-1800 kgf. <i>bs</i>
4	12.10.78 TYPE # ADDED

Drawing Number – W4
Outline Number – 100A243

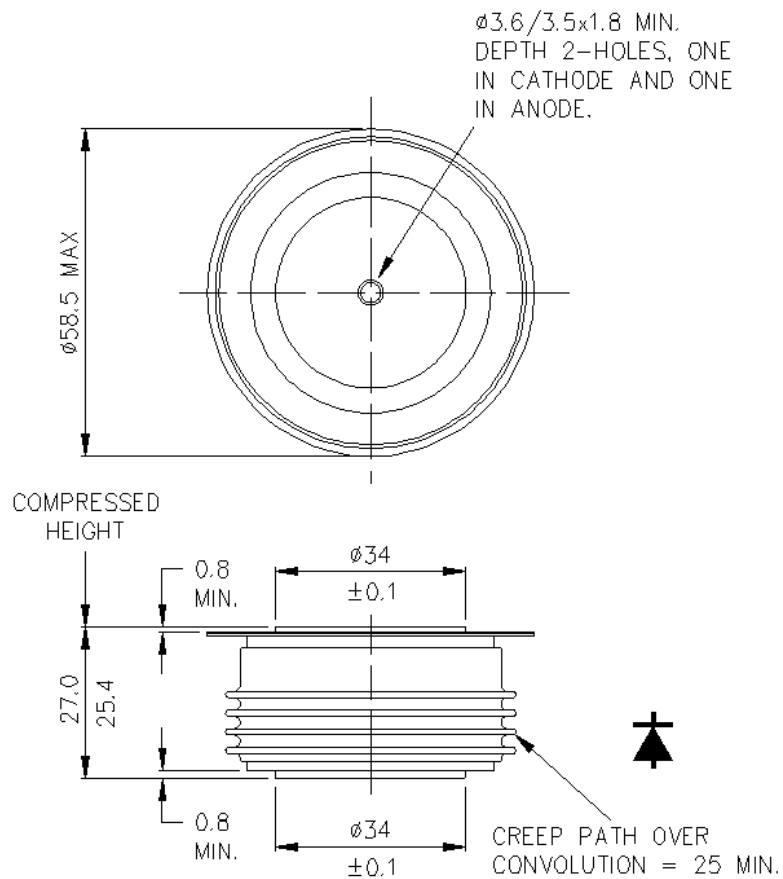

Weight 340g